



INTERDISCIPLINARY
**INTERACTION
DESIGN**

A VISUAL GUIDE

TO BASIC THEORIES, MODELS
AND IDEAS FOR THINKING AND
DESIGNING FOR INTERACTIVE
WEB DESIGN AND DIGITAL
DEVICE EXPERIENCES

JAMES PANNAFINO

Introduction

Interactive design tends to be an umbrella term, often used in higher education and industry to encompass multiple disciplines that fall into the interactive realm. Interaction design is one of interactive design's subsets and can be described as the design of digital devices, interfaces and the interaction of the user and said design. Interaction design was coined by Bill Moggridge and further explained and studied by Alan Cooper in his book *About Face 3: The Essentials of Interaction Design*. Interaction design can be seen in various disciplines such as psychology, human computer interaction, user experience, industrial design and many others (Figure 1).

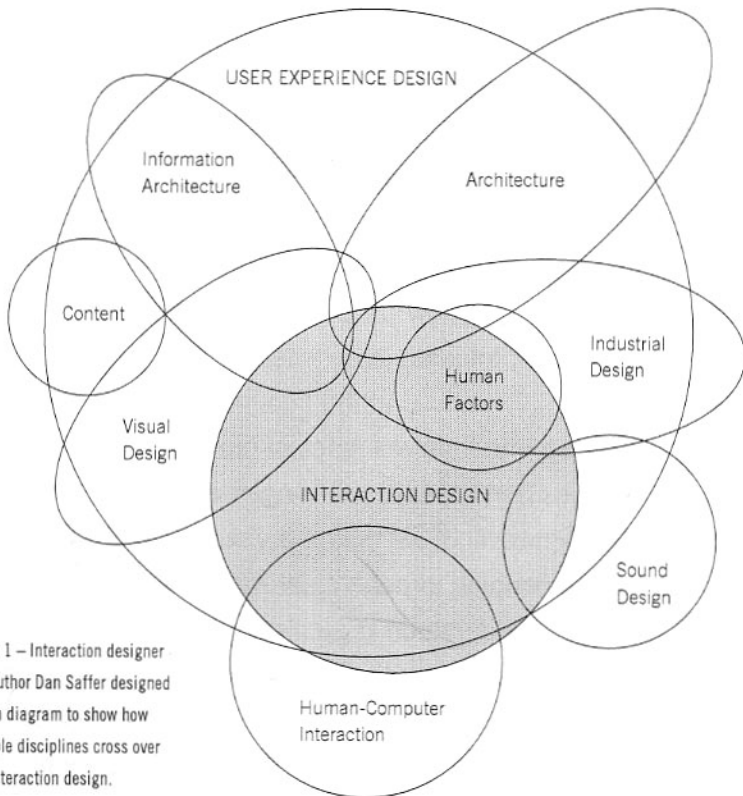

Figure 1 – Interaction designer and author Dan Saffer designed a venn diagram to show how multiple disciplines cross over into interaction design.

This book further explores the idea of interaction design across disciplines and the various principles that can help with the application of timeless theories in the interactive design process. It also explores less represented disciplines that relate to interaction design such as comics, gaming, motion design and business, to name a few. It uses visual translation, metaphors and concise explanations to create a guide for users to start to grasp various theories. These concepts explore interaction between humans, computers and information as a whole. This entails how we see and understand words, the meaning of imagery, how space and time affect interaction and human behaviors and how our information and digital devices affect our actions within the world and objects that surround us.

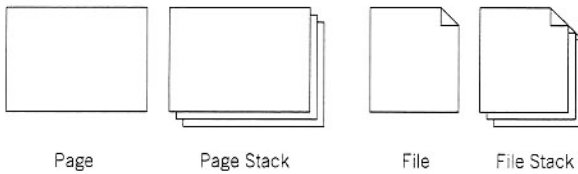

Figure 2 – User-experience expert Jesse James Garrett created the well-known “Visual vocabulary for describing information architecture and interaction design.” Basic units of presentation (left).

Due to the interdisciplinary nature of this project, each discipline can take away its own meaning or usage from the examples in this book. My hope is that this book adds to the basic foundation (Figure 2) of interdisciplinary principles and theories for interaction design thinking across disciplines; that it also continues to create a visual language for the better understanding of complex principles; and that it is a starting point for further exploration of each term’s meaning.

All the best,
James Pannafino

Affordances

When objects or designs signal properties or functions, the affordance describes to us what they are used for or what they do. A handle on a drawer allows (or affords) us to push and pull the drawer. Similarly, a button on a digital page affords us to press it. If the affordance is used properly, a basic task should be easily utilized. When a basic affordance is too complex and needs more description, then the affordance no longer informs the user about the design's purpose. Also see Signals and Cues.

Physical Affordances



A vertical crossbar on a door affords the user to open the door by pushing.

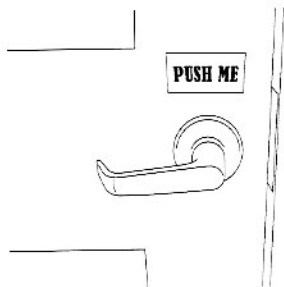

The handle signals pull, but the function does not afford the user to complete the task; it needs further explanation and fails as a basic design.

Digital Affordances

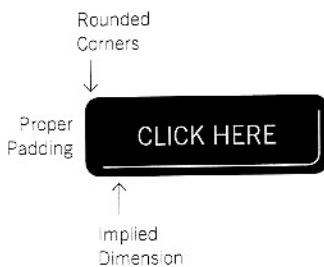

FORM / DIMENSION

Familiar shape and dimension of buttons afford users the ability to click that area to create an interaction.
 Note: This is just one of many possible examples.

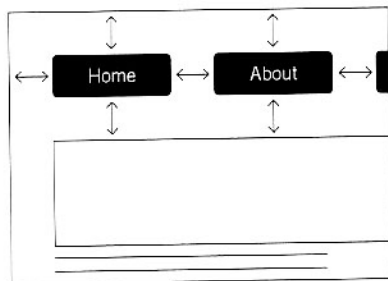

PROXIMITY

Proper spacing between navigational elements and content affords the user the ability to click a button.

Button Interaction States

The following are three examples of button interaction states. The first is an analog button, which is commonly found on keyboards, alarm clocks and various power buttons. The second is a digital interface button, which is often seen on digital tablets and mobile phones. The last is a standard GUI interface where the user manipulates a mouse or track pad to control an arrow on screen. Also see Affordances and Signals and Cues.

Analog Button Interaction

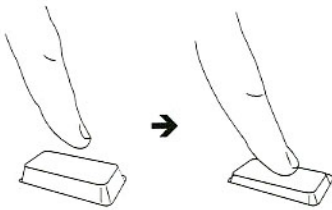

The Static state extends up off the interface to physically signal it is a button.

The Clicked/Pressed state is activated when the user presses down on the button.

Digital Button Interaction

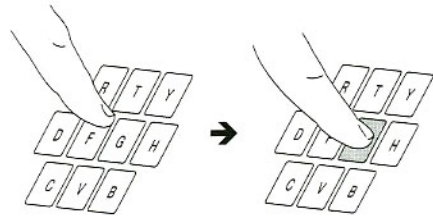

While still physically activated by hand, the Static state is flat on most digital devices.

When Clicked/Pressed, the button is activated. In some cases an audible sound is also made.

Computer Button Interaction States

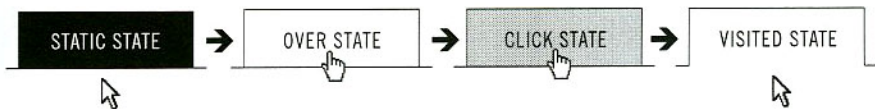

The first is the Static state when the user's mouse is not engaged with the button.

The second state is the Over/Hover state when the user moves/hovers the mouse over the button.

The third state is the Clicked/Pressed state when the user activates to visit another page.

The fourth state is the Visited state when the user has visited the page he selected.

Chunking

When writing and designing large amounts of information for a digital experience, it helps to envision the content into topics and subtopics and avoid reflecting a long form document (such as a printed novel). The strategy of chunking information into smaller parts is used to afford users the ability to scan information. There are various ways to chunk information such as writing short paragraphs and sentences, highlighting key phrases or creating bulleted lists. Chunking creates an organized format that helps users predict future sections of the digital page yet to be explored.

Running Paragraph

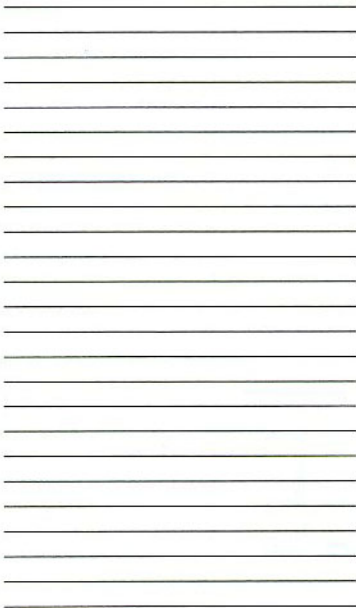

A long running paragraph has no visual hierarchy and does not have areas for visual rest.

Chunking Information

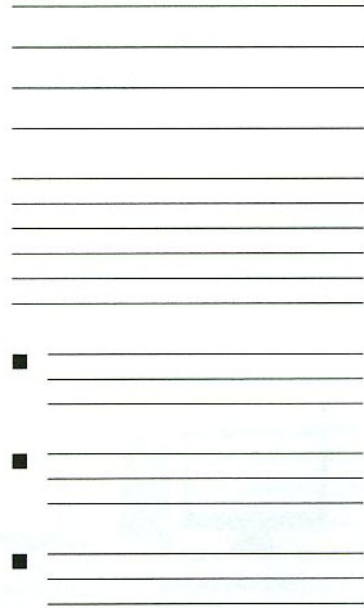

By creating emphasis on the intro paragraph, using bullets and separating content with visual rest, the user has a proper structure to read from.

Cognitive Load Theory

Cognitive load theory refers to the amount of new information our working memory can hold and the amount of tasks it can process. Long-term memory is something we store and use in a later time. Designers work towards the hope that the user will be able to transfer information from working memory (a designer-created task) to the long term to be recalled later and at a faster pace when revisiting that task. A designer wants to avoid overwhelming the users with too much information, so they don't give up.

Miller's Magic Number 7

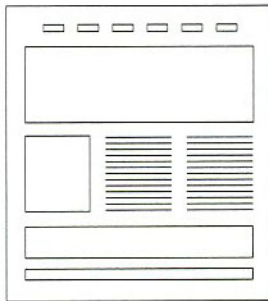

Psychologist George Miller is theory “The Magical Number Seven, Plus or Minus Two” refers to how a person’s memory span can only hold around seven objects. A well-designed menu will limit features and break information into sections (left). Similarly a more manageable digital experience might have a limited number of primary navigation links (right).

Information Overload

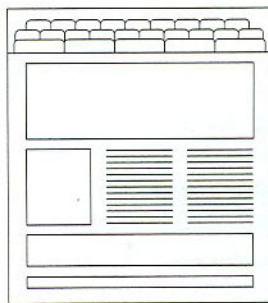
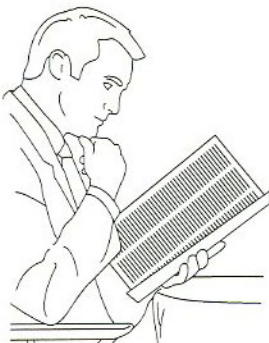

Author Alvin Toffler discussed “Information Overload” where the senses are overwhelmed, and decisions are stifled because a person is unable to process the information. A menu with too many choices may cause a patron to be indecisive (left). In a digital interface, too many buttons in one nav bar may cause the user to leave the site or choose the wrong link (right).

Controls

Controls are common components within screen-based interface design that allow the user to change, adjust or manipulate interface content. Controls can fit into different categories¹ (see below), working either together or separately. While users might be familiar with standard controls, the use of them does not equal good design and should only be used in the right situation. Below are just a few different types of examples of controls.

Action based Controls



Action-based controls can be seen in controls that take a direct action. Buttons and links are examples of action-based controls.

Selection-based Controls



Selection-based controls allow the user to select one or more choices on screen. An example is a list of check boxes; the user can click on and off the box as needed.

Input-based Controls



Input-based controls allow the user to enter information into a bound or unbound field of entry. Spin boxes are an example of both; the arrow buttons form bound increments and the field leaves it open for unbound entry.

Display based Controls

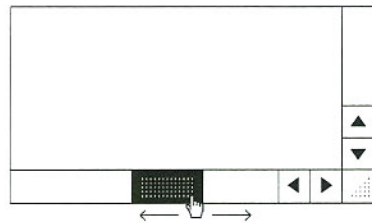

Display-based controls help operate the displays within an interface design. A common example are scrollbars that allow users to access information beyond the portal of visibility.

¹ About Face 3: The Essentials of Interaction Design™ Alan Cooper, Robert Reimann and David Cronin

Entry Point

An effective entry point is important for first-time users because there may only be a few seconds to entice them to use a digital interface or enter a Web site. Entry point designs should have a clear hierarchy, and the decision choices should direct the user to a path within the content. A good analogy¹: would a potential shopper be more enticed to enter a business storefront with an inviting, well-designed entry point or one with a lot of visual noise and confusion?

Physical / Storefront Entry Point

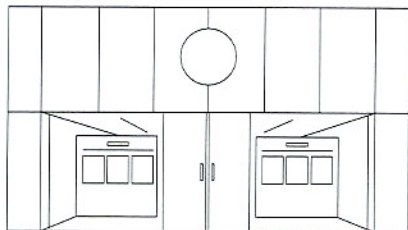

A clear entry point, has a balanced hierarchy and inviting visuals' support system. The branding is front and center with a strong product presence.

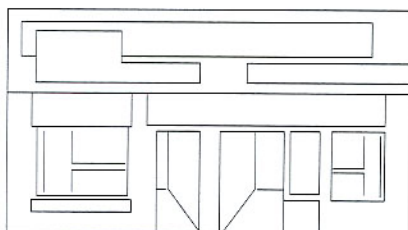

Overwhelming visual information, multiple points of entry, varying signals and no clear product preview might deter the shopper from entering.

Digital Interface Entry Point

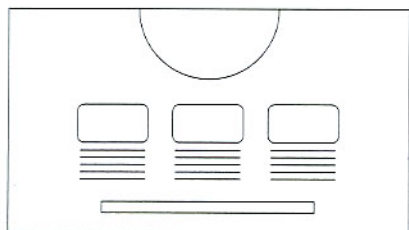

A well-designed entry point has a balanced hierarchy and clear decisions points for the user to select.

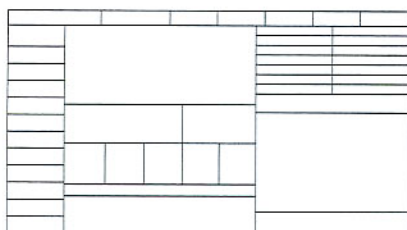

Too many decisions with no sense of hierarchy makes it difficult for the user to make a clear choice.

¹ Entry Point / Storefront analogy: *Designing Effective Entry Points in Web Design* by Brandon Jones via tuts+

Feedback

When a user has indicated an action or completed a task, the system or product will respond to the user to reinforce that action has happened. Feedback can be communicated in various reaction times (sometimes milliseconds) and different forms, such as an auditory sound, physical action, verbal response, visual cue or a combination. Feedback can help in relaying if a choice was positive or negative in the user's experience.

Visual and Auditory Feedback

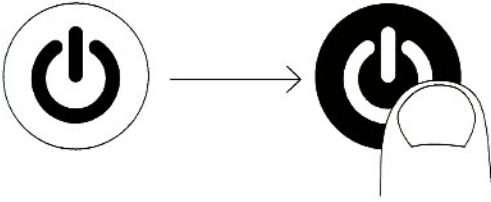

In this example, a user presses a universal power button and receives feedback visually through light and auditory by a "bing" or "bong" sound depending on the device.

Data/Information Process Feedback

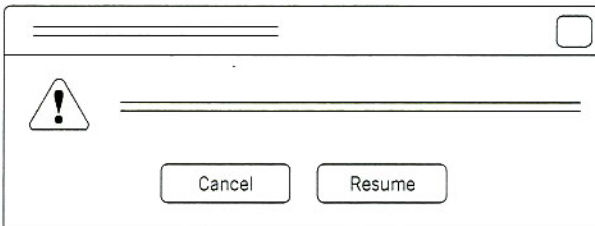

A popup dialogue box is a type of visual feedback that tells the user that there needs to be more information inputted into a field or redirect the course of action.

Flowchart

Flowcharts represent a sequence of steps of a given operation, action or process. They use a series of graphics that include geometric shapes, arrows and reference keys to describe their function.

Flowcharts may allow groups to build a common understanding, improve upon current processes and create a greater consistency in their workflow. Flowcharts show a basic view of information flow, where a data flow or usability diagram shows a higher level of system flow/complexity.

Online Banking Flowchart

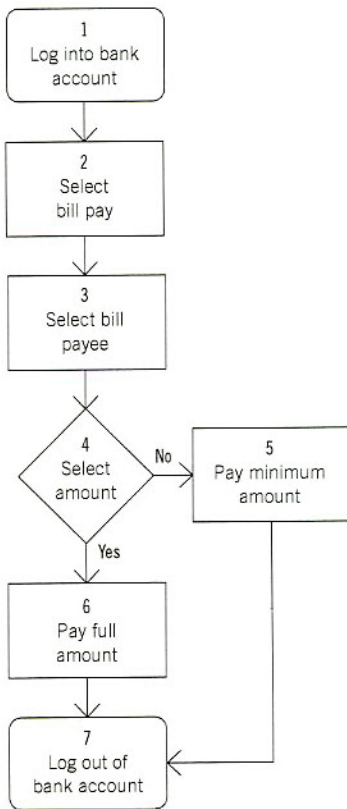

Flowchart Symbol Key ¹

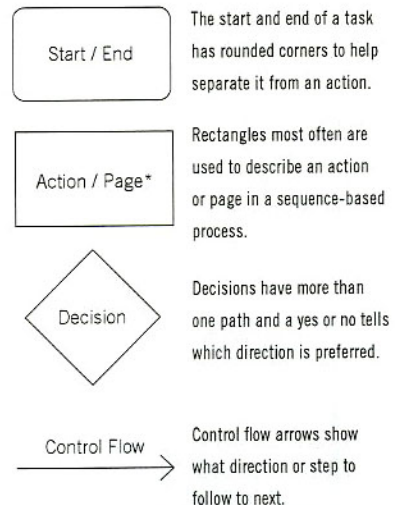

* Rectangles can be interpreted as an action/ task or page ² depending on if context is based on user choices, document flow or a combination of the two.

¹ Flowcharts: Plain & Simple: Learning & Application Guide by Joiner Associates Staff, p. 12
² Jesse James Garrett's – A visual vocabulary for describing information architecture and interaction design

Frame Mobility

Frame mobility¹ is the concept of dividing a larger scene or object into separate divisions while continuously keeping part of the subject within the viewing frame. By breaking down the larger context, it allows one to show a process, build a narrative or create a preview onto what will happen later. To help stage the content, text may accompany the scene when it pauses or stops for visual rest.

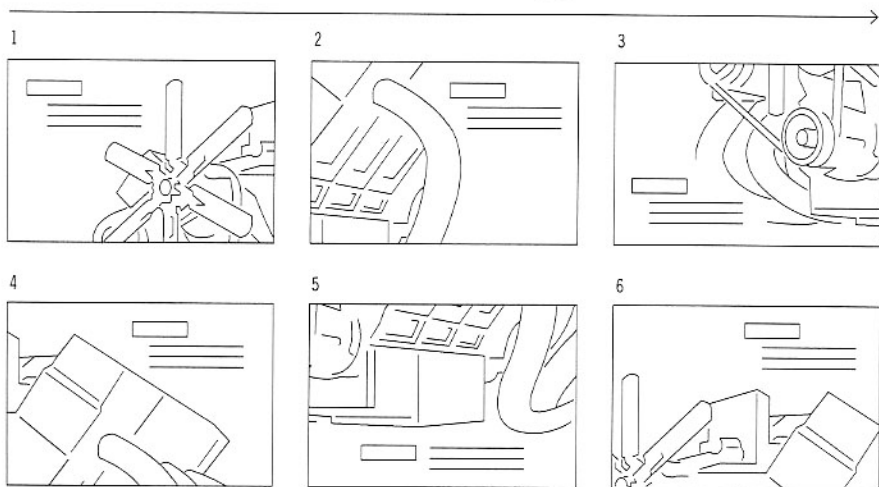
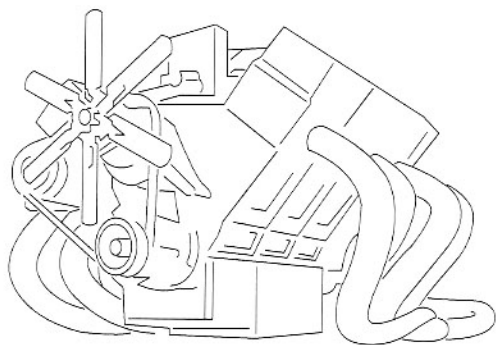

The above example shows a car motor as a whole. The following panels show it in a motion sequence broken down into separate scenes, with titles and written descriptions.

¹ Motion Graphic Design: Applied History and Aesthetics by Jon S. Krasner

Hick's Law

Hick's law was named after psychologist William Hick and states that the more choices one has, the more time it will take to process a decision. While some people might want more options, their reaction time will be slowed and sometimes even stopped due to all the different choices. There are many factors that go into the effects of Hick's law such as a person's experience, the type of choices, the category of choices and the way they are presented.

Grocery Store Jams Sampling ¹



A study found that customers are less likely to try a smaller sampling, but those who do try are more likely to purchase jams if the sampling choices are limited to 6.



If there are 24 to 30 choices of jams, there is a higher chance of someone sampling them, but a lower chance of a jam being purchased. This illustrates that more choices is not always better, if the end goal is to have someone purchase the jam.

Digital Interface Menu

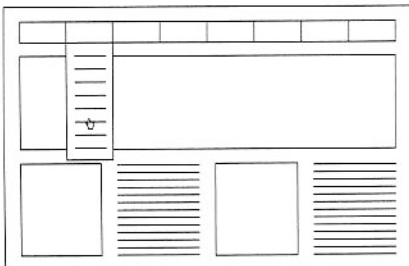

Users may be more willing to use a drop-down menu that is a single list and with limited choices.

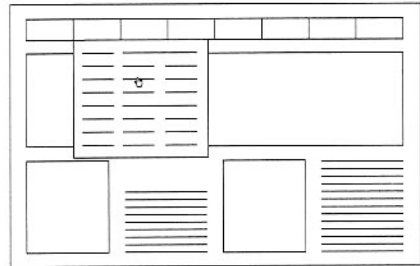

A larger fly-out menu with multiple columns and subdivisions may be overwhelming, more difficult to make a correct choice, and in some cases may cause the user to opt out from searching.

¹ Iyengar, Shena S. and Mark R. Lepper 2000. When choice is demotivating: Can one desire too much of a good thing? *Journal of Personality and Social Psychology*. 79:995-1006)

Personas

Personas are a type of user model that allow designers to predict how users will act and think, and why they want to accomplish a given task. Personas are a composite archetype and not based on a real person, but a combination of motivations and behaviors. They are not made up and, if done right, are based on factual data recorded beforehand in the observation research stage. In the end the persona will address a specific type of person (not one specific person) and not a random group of users.



"I get very frustrated when I cannot find what I am looking for."

Frank

Demographics

Age: 55

Occupation: Teacher

Location: White Plains, NY

Goals

Wants to find discounts online.

Doesn't want to spend a lot of time on one page.

Prefers newer products over old products.

User Behaviors

Scans through reviews of products quickly.

Likes to share deals (information) with others.

Gets distracted easily.

Personas can help designers to determine, communicate and measure a product's goals or usage. While personas vary in range of content, they tend to always have a person's name, photo, quote and basic demographic information.

Scanning vs. Reading

While specific situations (goals, time or user experience) differ greatly, studies¹ have shown that users tend not to intently read a Web page as they would a printed book; they merely scan the page. In his book *Don't Make Me Think: A Common Sense Approach to Web Usability* Steve Krug discusses how users make sacrifices and choose the most reasonable option². Sacrifices are made because if the option they choose does not work, they can go back a page and try again with no real negative consequences. Clear hierarchy is key to establish levels of importance and reading direction.

Gutenberg Z

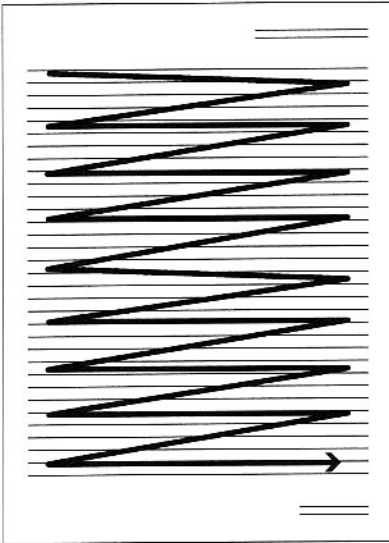

A typical long form print reading experience (in Western languages) might look like the above. Gutenberg Z pattern works left to right and top to bottom. This experience is void of interactive functions and major distractions.

Digital Scanning Experience

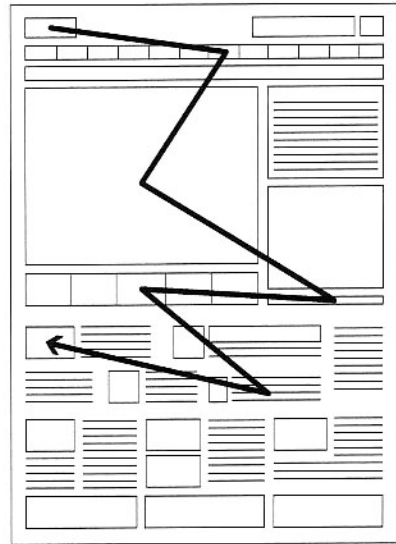

In most cases the user will scan the Web site or digital interface until something closely meets what he is looking for and choose that.

¹ <http://www.poynter.org/extra/eyetrack2004/viewing.htm>

² *Don't Make Me Think: A Common Sense Approach to Web Usability*, by Steve Krug

Sequence and Motion

To understand sequence and motion, going beyond a definition is essential. There must be an understanding of their relationship and the differences between the two. The discipline of film and animation (the process of making a motion picture) needs to be analyzed. Through persistence of vision, sequence becomes motion.

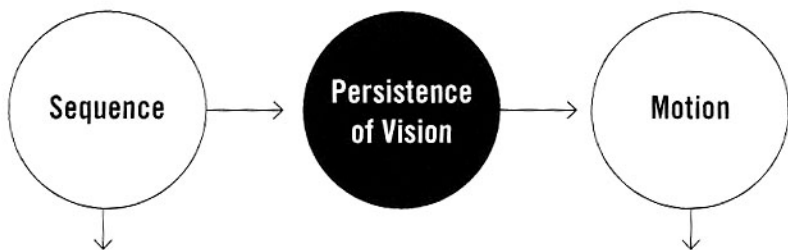

LINEAR SEQUENCE

The audience can view the content straight from beginning to end, or backwards from end to beginning.

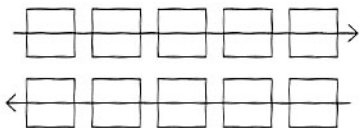

NON-LINEAR SEQUENCE

The audience can view the content simultaneously. Non-linear perception allows the audience to interpret the content in a variety of ways.

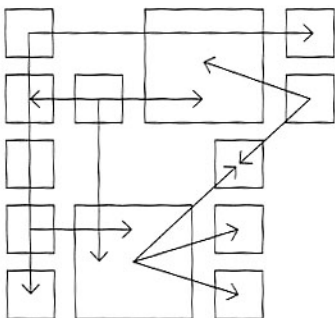

SINGLE FRAME

The arrangement of content in a single frame format that is shown in a rapid progression to fool the human eye into thinking that it is perceiving kinetic movement.

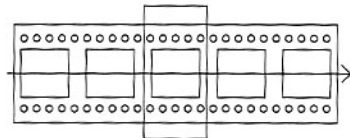

LINEAR MOTION

Motion can only be perceived in a linear fashion. The audience can view the content straight from beginning to end, or backwards from end to beginning.

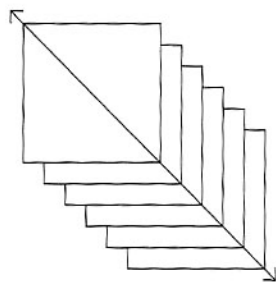

Sequence Mapping

In her book *Designing Interfaces*¹, Jenifer Tidwell used the term sequence mapping as a way to label multi-step selection processes. Sequence mapping serves as two functions, showing where a user is at in a step-by-step experience and how much progress still needs to be done. In most cases sequence mapping is a linear process that has a concise description of what each step is, number in process and allowing for back and forth selection between multiple steps.

Steps Left

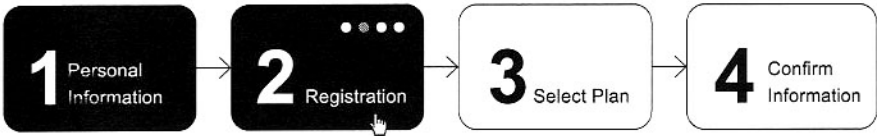

This multi-step process shows what steps were taken (in black) and where the user is (dotted highlight) at in the overall progress. This type of sequencing is seen in application or sign-up processes. It is most often seen at the top of a page's design.

Pagination

« 1 2 3 4 5 6 7 8 ... 125 225 »

- or -



Web sites that have multiple pages such as articles, online forum or long-form page documentation are often created dynamic text but can vary in style. This form of sequence mapping is seen at the bottom of the page.

¹ *Designing Interfaces: Patterns for Effective Interaction Design* by Jenifer Tidwell

Site Map

Site maps are diagrams that show the flow information and structure of how pages on a Web site are grouped and organized. They allow the stakeholders to see the high-level view of a site, whereas wireframes allow for a page view. While site maps appear simple in design, one should always maintain proper alignment, text placement and a correct labeling/number system. If a site map becomes more complex, notations or a legend might be necessary.

Basic Site Map Example

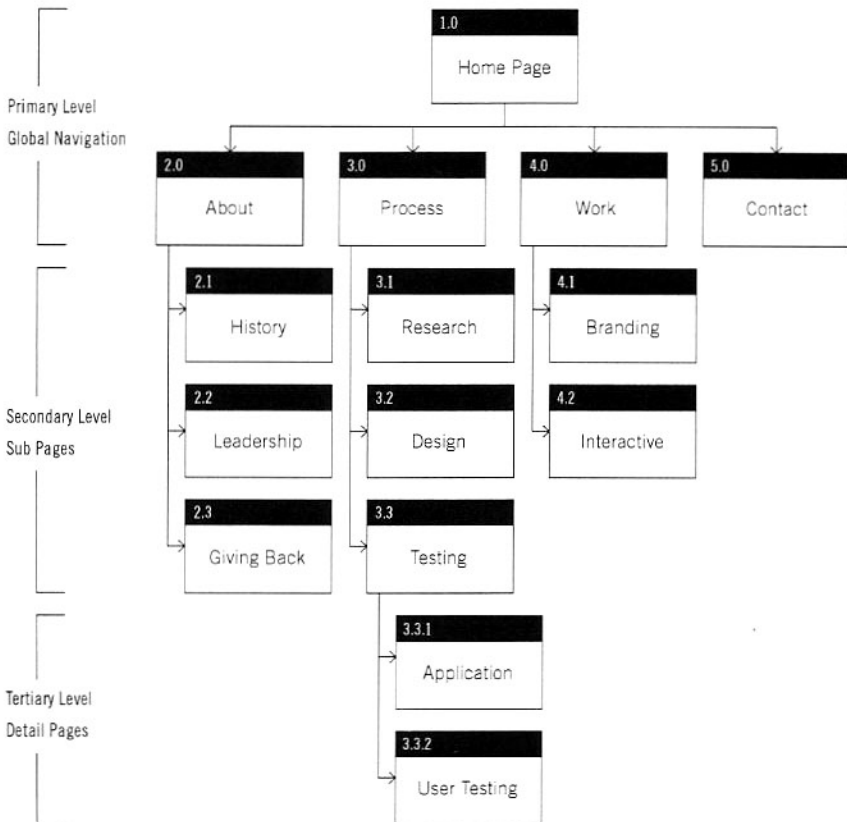

While a site map may look like a simple arrangement of boxes and lines, it's the subtle details that can make the page-to-page communication clear or confusing. Below are some examples of common mistakes made when creating a site map.

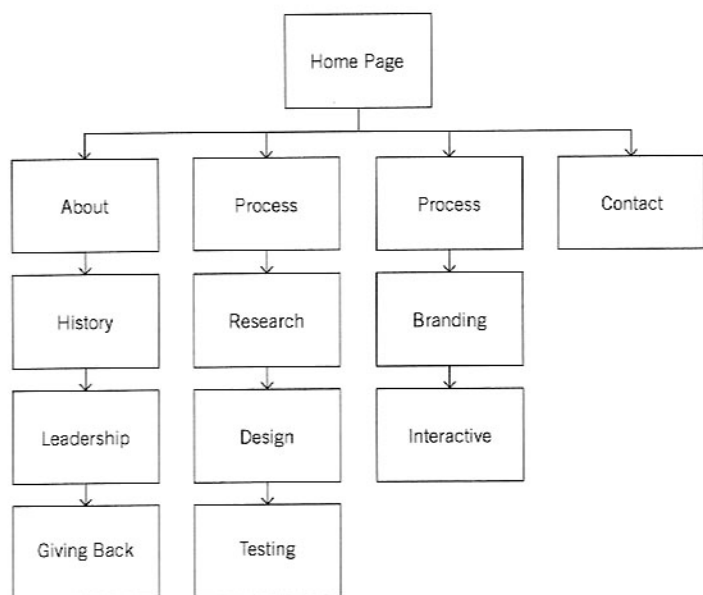

One continuous line through multiple pages communicates a forced linear option for the user. There is no way to navigate across all the pages in one click.

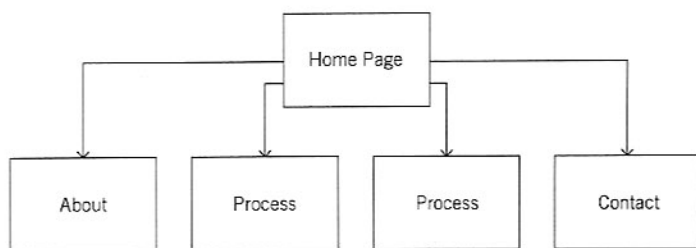

The above example shows the lack of global navigation. The user must go back to the home page before being able to select other sections.

Wireframes

Wireframes are essentially prototypes of Web sites, applications or digital device interfaces. They act as a blueprint for content structure and sometimes describe functionality. In most cases wireframes do not have any styling or finalized visual design elements. By creating wireframes before the design stage, the stakeholders can focus on content hierarchy, make quicker iterations in content placement and validate various ideas.

Basic Wireframe / Standard Components

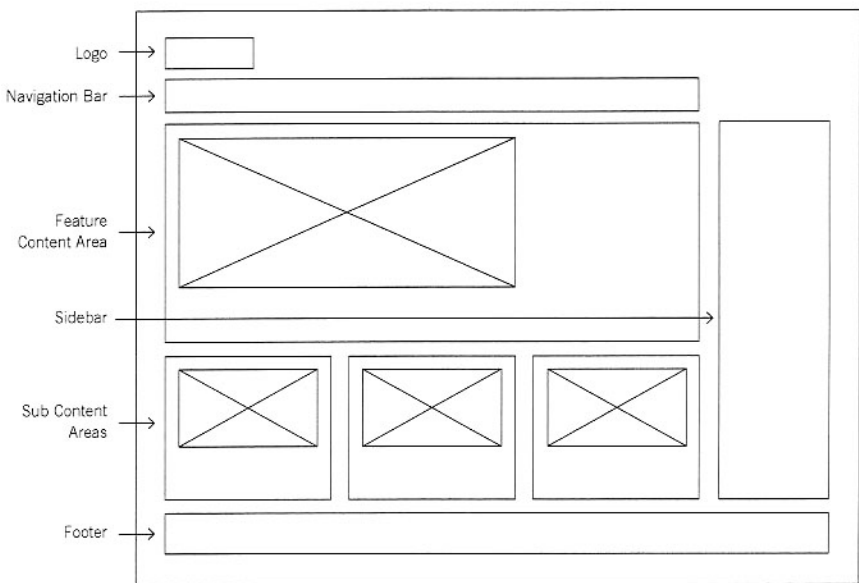

Basic wireframes will show navigational elements, content areas and image placement without stylized details. Each section should have a label describing what it is.